

**Supratec**

Gesellschaft für Umwelt-  
und Verfahrenstechnik mbH

# OXYFLEX<sup>®</sup> - MF 1100 MEMBRANE PLATE DIFFUSER



# Supratec

GESELLSCHAFT FÜR UMWELT-  
UND VERFAHRENSTECHNIK MBH

**AERATION TECHNOLOGY**



**STONE FOOD  
MACHINERY LTD**

VAL W. STONE B.Agr., Sc.  
The Bull Ring, Wexford, Ireland.  
(Intl): Mobile +353 86 2570492  
Tel +353 53 91 47800 Fax +353 53 91 47799  
Email: valstone@stonefoodmachinery.com  
Web: www.stonefoodmachinery.com

von-Drais-Straße 7  
D-55469 Simmern / Hunsrück

tel.: +49 6761 / 9 65 09-00  
fax: +49 6761 / 9 65 09-01

e-mail: [info@oxyflex.de](mailto:info@oxyflex.de)  
internet: [www.oxyflex.de](http://www.oxyflex.de)

## **OXYFLEX® - MF1100**

### **MEMBRANE PLATE DIFFUSER**

The OXYFLEX® - MF1100 membrane plate diffuser consists of a flat, heavily ribbed and fibreglass-reinforced polypropylene base plate. The diffuser membrane is secured to the base plate with a two-part frame made of fibreglass-reinforced polypropylene. The high-quality injection-moulded membranes are available in

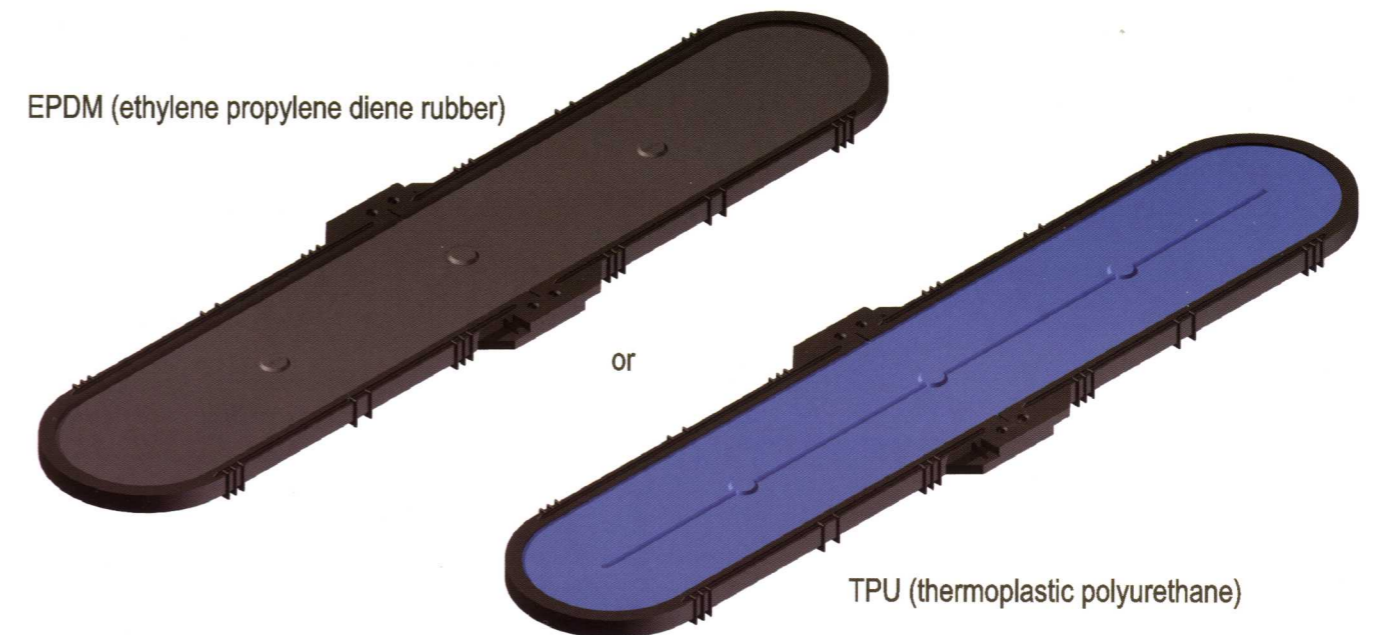

The OXYFLEX® - MF1100 membrane plate diffuser has an active flat membrane surface of 0.2 m<sup>2</sup>.

In contrast to the tube diffuser, the entire active surface of the plate diffuser is at a hydraulic level. Even for different specific air loads, the entire membrane surface always works evenly.

The special design of the OXYFLEX® - MF1100 membrane plate diffuser ensures that there is only a small pressure loss, which increases very slightly over the service life of the equipment. As a result, apart from the service life, the efficiency is also significantly increased compared to other diffuser types.

The OXYFLEX® - MF1100 membrane plate diffuser is characterised by the following superior features:

- ➔ highly efficient oxygen transfer
- ➔ low and stable pressure loss
- ➔ special diffuser design that is adaptable to all conditions
- ➔ easy cleaning of the membranes resulting in
- ➔ low-maintenance operation

The OXYFLEX® - MF1100 membrane plate diffuser is a highly efficient aeration element, which is predominantly used for the oxygen supply of biological waste water treatment plants.

Due to the availability of the diffuser membranes in both EPDM and TPU materials, the OXYFLEX® - MF1100 membrane plate diffuser, which has a highly variable design, can also be flexibly used with regard to different water qualities and customer requirements.

Of course, the OXYFLEX® - MF1100 membrane plate diffuser can also be operated in intermittent mode.

The membranes are perforated individually and specifically for each project in order to achieve the perfect oxygen transfer for all requirements. The OXYFLEX® - MF1100 membrane plate diffuser is able to cover a very broad operating range of up to  $20 \text{ m}_N^3/\text{h}$  for each diffuser ( $\Delta 100 \text{ m}_N^3/\text{h}$  per  $\text{m}^2$  of membrane surface). With the fine-bubble design, specific oxygen transfer rates in pure water of more than  $30 \text{ g O}_2/(\text{m}_N^3 \times \text{m}_{\text{ET}})$  can be achieved by an area-covering layout and appropriate water depths.

Actual operating values show that this highly efficient diffuser system is able to achieve standard aeration efficiency (SAE), which are significantly above the current DWA-M 229-1 guidelines. For example, an oxygen yield of  $5.8 \text{ kg O}_2/\text{kWh}$  was demonstrated for a waste water treatment plant size of approx. 28,000 EW. These extremely good SAE are also due to the comparatively small pressure loss of the diffusers.

As an option to fine-bubble aeration, the membrane can also be manufactured for a coarse-bubble version.

The following diagram shows the example of a result of an oxygen transfer test. The values were measured in a round tank with a water depth of 5.0 m, a diffuser blow-in depth of 4.8 m and a coverage of 21%.

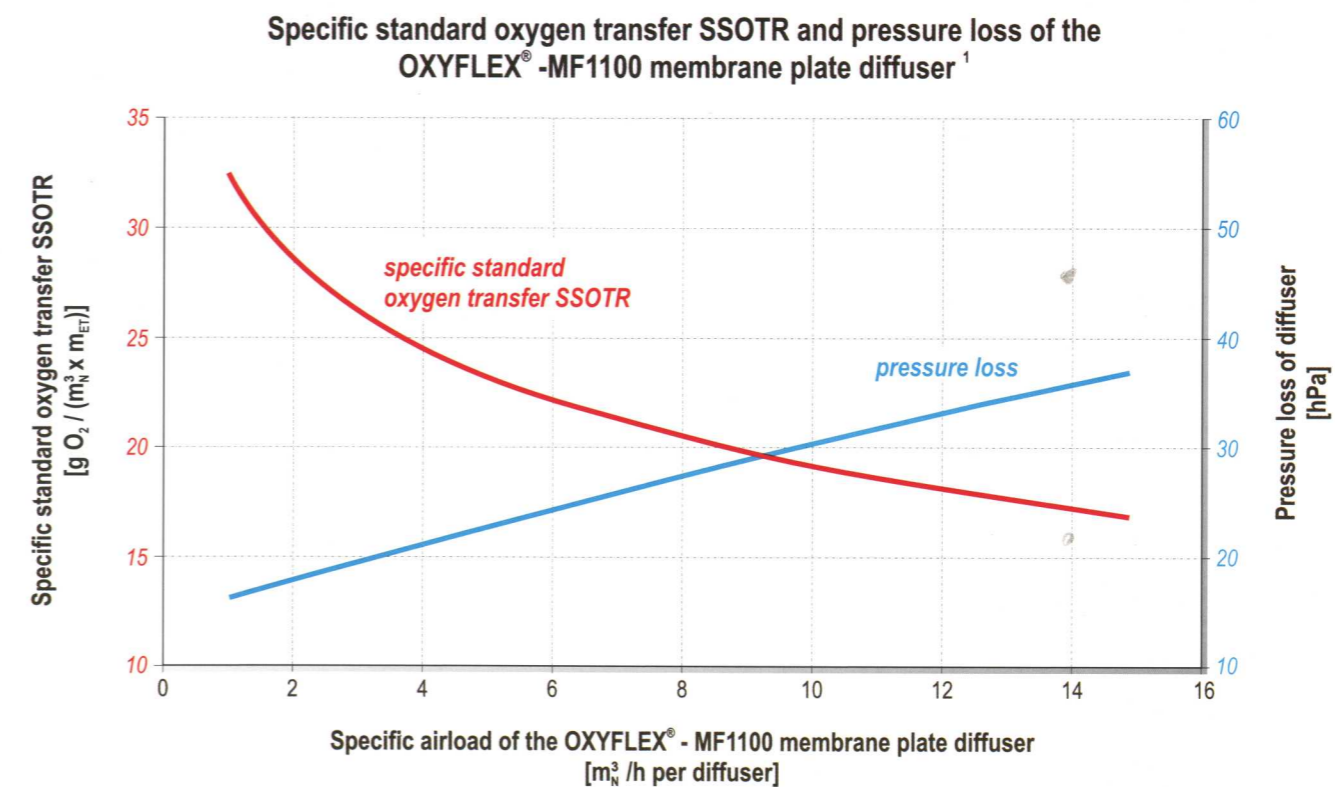

These values cannot be transferred to other plants. The results that are shown here depend on several influencing factors, such as the tank shape, blow-in depth, coverage or a separate recirculation due to additional mixers.

Supratec will be pleased to prepare a technical data sheet for each individual application for you on request.

<sup>1</sup> The diagram cannot be used in order to derive warranty claims of any kind.

#### **AIR-PULSING: mixing without a mixer**

The option of the intermittent operating mode means that, in a combined tank with alternating nitrification and denitrification phases and for a sufficient coverage by OXYFLEX® membrane plate diffusers, the use of a mixer may be not necessary ("Air-Pulsing" process).

Any sedimentation of the activated sludge during the denitrification phase is prevented by short-term aeration intervals. The required aeration intervals are individually adapted to the respective plant with regard to its specific conditions such as the sludge index of the waste water. The aeration time is up to 20 seconds and the process is repeated approximately every 10 to 20 minutes depending on the plant type.

#### **CLEANING**

The OXYFLEX® - MF1100 membrane plate diffuser is a low-maintenance system and is partially self-cleaning due to the different specific air loads during the normal operating cycle. Any deposits are removed by short-term load-dependent changes of the membrane extension. This also prevents any accumulation of biological growth. If the normal operating mode is insufficient for cleaning, we recommend that an additional maintenance cycle is introduced at regular intervals. This maintenance cycle depends on the project and can either include a short-term maintenance load or short-term pressure relief with subsequent quick restart up to full-load operation.

This maintenance cycle is also used for removing deposits after longer periods of inactivity and long-term operation with low specific loads.

#### **ACID DOSING**

For plants, for which limescale deposits are to be expected, we recommend that these plants are cleaned with diluted acid (85% formic acid for EPDM membranes or 30% acetic acid for TPU membranes) at regular intervals. The diluted acid is dosed into the compressed air if required. Our experience shows that these activities will reduce the membranes' pressure loss and extend their service life. For this purpose, we offer a dosing station for perfectly dosed cleaning.

Please contact Supratec for further information about acid dosing.

## INSTALLATION OPTIONS

The OXYFLEX® - MF1100 membrane plate diffuser is suitable for installation on stainless steel pipes and plastic pipes and can therefore be used easily for all existing and new plants.

Due to the large variety of installation options for round and square pipes, the OXYFLEX® - MF1100 membrane plate diffuser also allows the easy upgrading and efficiency increase of existing aeration systems while maintaining existing pipelines and minimising costs.

The optional side brackets allow an area-wide coverage irrespective of the installation type (round or square distribution pipe) near the mixer.



The OXYFLEX® - MF1100 membrane plate diffuser is also available in a standardised number of 10 individual elements as an aeration unit with an active membrane surface of 2 m<sup>2</sup>: OXYFLEX® MF2,0.



This 2-m<sup>2</sup> diffuser, whose length can be adapted to the respective tank geometry, can be adapted to specific requirements regarding the size of the active surface by changing the number of individual elements.

The OXYFLEX® - MF1100 membrane plate diffuser has been used successfully in Germany and worldwide in communal and industrial waste water treatment plants for many years. It is also suitable for aerating liquids of all kinds, such as the neutralisation of sea water during wet flue gas desulphurisation (sea water FGD) or similar applications.

We will be pleased to send you our current list of references on request.

### ILLUSTRATION

**Materials:**

Membrane: EPDM (ethylene propylene diene rubber)  
TPU (thermoplastic polyurethane)

Base plate: Polypropylene (PP-GR)

Frame: Polypropylene (PP-GR)

Seals: EPDM

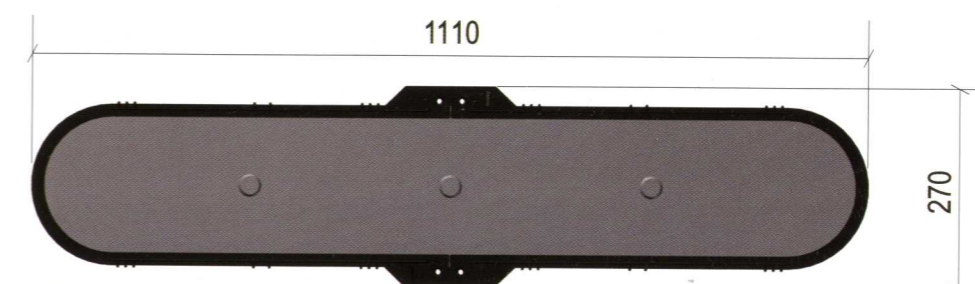

Membrane surface: 2 m<sup>2</sup>

### "AS" TYPE FOR INSTALLATION ON ROUND PIPES

The OXYFLEX® - MF1100 "AS" membrane plate diffuser is fixed to round pipes using a clamp saddle that is welded in the factory.

The integrated installation aid and non-twist angle of the clamp saddle allow an easy installation. The clamp saddle is closed by a joint lock and one hexagonal head screw.

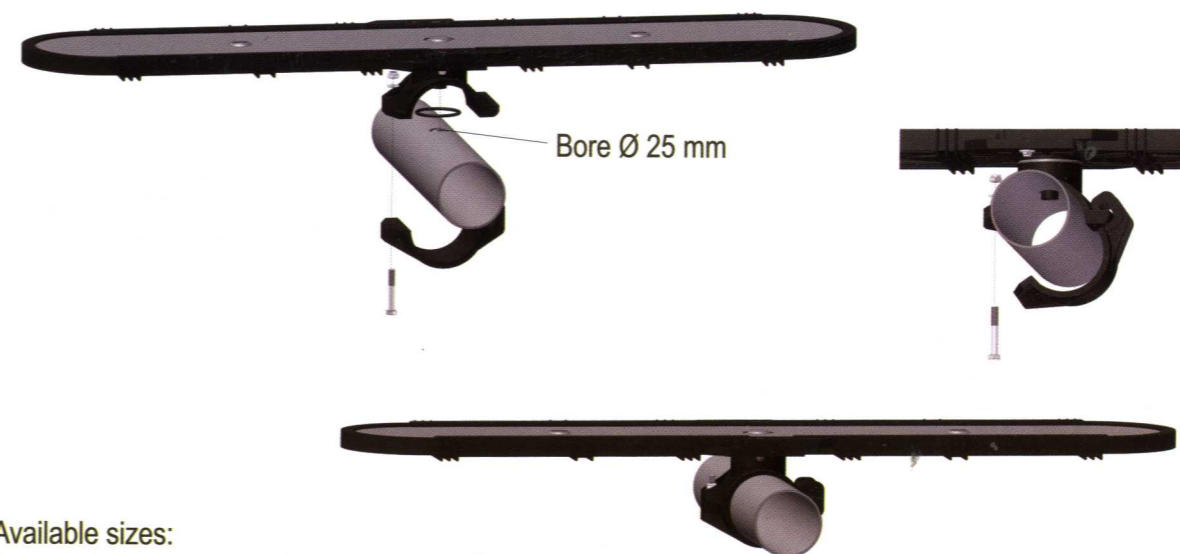

**Available sizes:**

for stainless steel pipes: DN 65 - DN 125<sup>2</sup>

for plastic pipes (outside Ø): 75 mm - 160 mm<sup>2</sup>

(Further sizes are available on request.)

<sup>2</sup> For usable pipe sizes please see table "[http://supratec.cc/de/plattenbeluefter/oxyflex\\_mf1100.aspx](http://supratec.cc/de/plattenbeluefter/oxyflex_mf1100.aspx)"

## "B" TYPE FOR INSTALLATION ON SQUARE PIPES

The OXYFLEX® - MF1100 "B" membrane plate diffuser is installed on square pipes using thread bolts.

The 4 welded thread bolts ensure a permanent and stable position of the OXYFLEX® - MF1100 membrane plate diffuser.

The bolt installation can be used for existing square pipes (with a minimum width of 60 mm) and adapted to a wide range of very different situations.

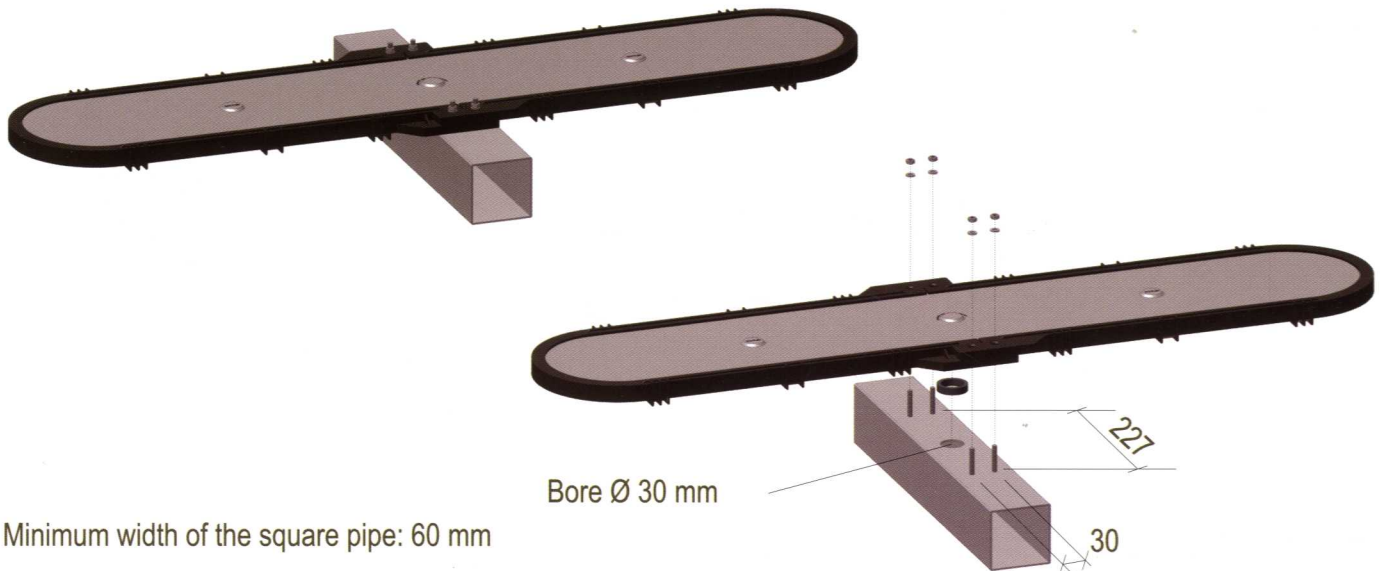

Minimum width of the square pipe: 60 mm

## "SA" TYPE FOR INSTALLATION ON SQUARE PIPES WITH SIDE BORES

The OXYFLEX® - MF1100 "SA" membrane plate diffuser is used for the easy replacement of tube diffusers using the existing square pipes.

The side adapter is used if side bores exist in order to allow the cost-effective upgrading by installing the OXYFLEX® - MF1100 membrane plate diffuser.

Variations of the side adapter allow the adaptation of this installation type to different conditions and situations.

Possible pipe dimensions:

Height: 80 mm, 100 mm or 120 mm

Width: 60 mm - 120 mm

(Further sizes are available on request)

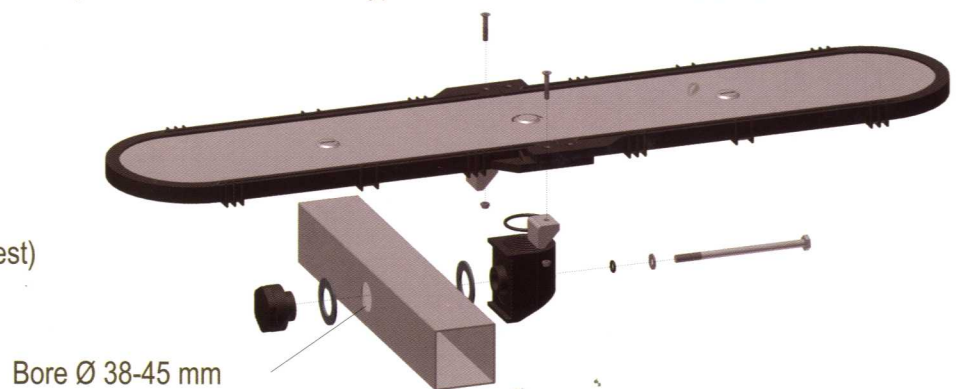

Bore Ø 38-45 mm

## FLEXIBLE CUSTOMISED SOLUTIONS

The development of customised fastening clamps allows the highly flexible adaptation of the OXYFLEX® - MF1100 membrane plate diffuser to project-specific conditions.



Wedge clamp  
for a metal-free installation

We will be pleased to support you with a customised solution for your application. Please contact us at any time.

## GENERAL INFORMATION

Supratec Gesellschaft für Umwelt- und Verfahrenstechnik mbH has more than 30 years of experience with aeration technology and manufactures state-of-the-art, highly efficient aeration systems. These products are predominantly used for providing the oxygen supply for biological waste water treatment processes but can also be used for the aeration of liquids of all kinds.

Possible areas of application for Supratec diffusers are:

- ➔ communal waste water treatment plants
- ➔ industrial waste water treatment plants
- ➔ special technical processes such as the "stripping" of gases, etc.

We have the competence and wealth of experience in order to consult and support you with the planning, implementation and operation of your projects.



We will also carry out gladly the installation of our products for you if required.



Our QMS is certified in compliance with  
DIN EN Norm ISO 9001

For further notes and special information please see the installation, operating and maintenance instructions.